

## MA.5.GR.3.3

Overarching Standard: *MA.5.GR.3 Solve problems involving the volume of right rectangular prisms.*

### Benchmark of Focus

MA.5.GR.3.3 Solve real-world problems involving the volume of right rectangular prisms, including problems with an unknown edge length, with whole-number edge lengths using a visual model or a formula. Write an equation with a variable for the unknown to represent the problem.

*Examples:* A hydroponic box, which is a rectangular prism, is used to grow a garden in wastewater rather than soil. It has a base of 2 feet by 3 feet. If the volume of the box is 12 cubic feet, what would be the depth of the box?

### Benchmark Clarifications

Clarification 1: Instruction progresses from right rectangular prisms to composite figures composed of right rectangular prisms.

Clarification 2: When finding the volume of composite figures composed of right rectangular prisms, recognize volume as additive by adding the volume of non-overlapping parts.

Clarification 3: Responses include the appropriate units in word form

---

### Related Benchmark/Horizontal Alignment

- MA.5.NSO2.1/2.2
- MA.5.FR.1.1
- MA.5.AR.1.1
- MA.5.M.1.1

---

### Vertical Alignment

#### Previous Benchmarks

MA.4.GR.2.1

#### Next Benchmarks

MA.6.GR.2.3

---

### Purpose and Instructional Strategies

The purpose of this benchmark is to solve real-world problems involving right rectangular prisms using a visual model or a formula. The real-world problems can require students to find an unknown side length or find the volume of a composite figure (MTR.7.1), if the figure can be decomposed into smaller right rectangular prisms. Students are expected to write an equation with a variable for the unknown to represent the problem. Similar expectations for area were developed in Grade 4 (MA.4.GR.2.1) and this work will be extended to include fraction and decimal side lengths in Grade 6 (MA.6.GR.2.3).

- Instruction of this benchmark can be combined with MA.5.GR.3.2 as students develop and apply understanding of calculating volume of right rectangular prisms using visual models and formulas (MTR.2.1).
- While finding volume, teachers should have students communicate and justify their decisions while solving problems (MTR.4.1).
- Instruction may include problems with the unknown side length being a fraction (MA.5.FR.1.1). For example, if a box has a base of 5in x 3in, and a volume of 20in cubed, what is the length of its missing side?
- During instruction teachers should allow students the flexibility to use different equations for the same problem. For example, to find the height of a rectangular prism with volume 120 and base dimensions 3 and 10, students can use any of the following equations:  $120 = 3 \times 10 \times h$  or  $120 = 30h$  or  $120 \div 30 = h$ .

---

### Common Misconceptions or Errors

- Students may confuse the difference between  $b$  in the area formula  $A = b \times h$  and  $B$  in the volume formula  $V = B \times h$ . When building understanding of the volume formula for right rectangular prisms, teachers and students should include a visual model to use to justify their calculations.
- Students may make computational errors when calculating volume. Encourage them to estimate reasonable solutions before calculating and justify their solutions after. Instruction can also encourage students to find efficient ways to use the formula. For example, when calculating the volume of a rectangular prism using the formula,  $V = 45 \times 12 \times 2$ , students may find calculating easier if they first multiply  $45 \times 2$  (90), instead of  $45 \times 12$ . During class discussions, teachers should encourage students to share their strategies so they can build efficiency.

---

### Questions to ask students:

- *How can you find the volume of a box if you do not have any cubes? Is there more than one way?*
  - Sample answer that indicates understanding: Measure the length, width, and height and multiply the length by the width by the height. You can also find the area of the base and multiply that by the height.
  - Sample answer that indicates an incomplete understanding or a misconception: Find the length of two edges of the bottom of the box.
- *What strategy can you use to find the volume of a composite figure (two figures put together to make one figure)?*
  - Sample answer that indicates understanding: Find the volume of each of the prisms separately then add them together.
  - Sample answer that indicates an incomplete understanding or a misconception: Find the length, width, and height of the whole figure and multiply them using the volume formula.

---

### Instructional Tasks

#### *Instructional Task 1*

The Great Graham Cracker Company places packages of their graham crackers into a larger box for shipping to area grocery stores. Each package of graham crackers is a right rectangular prism that measures 18 cubic inches. The base of each package of graham crackers measures 2 inches by 3 inches.

Packages are placed upright into the shipping box. Part A. If the larger shipping box is a cube with edges that are each 30 inches, how many layers of graham cracker packages can the shipping box hold? Show your thinking using a visual model and equation(s). Part B. Will the packages reach the top of the shipping box? If not, what will be the length of the gap from the top of the package to the top of the shipping box? Part C. How many graham cracker packages will fit in the shipping box?

### Instructional Items

*Instructional Item 1* Select all of the following that could be the dimensions of the base of a rectangular box with height of 16in and volume of 128in cubed.

- a. 2in x 4in
- b. 3in x 3in
- c. 1in x 8in
- d. 4in x 2in
- e. 56in x 56in

### Achievement Level Descriptors

Benchmark		Context	Assessment Limits
<p>MA.5.GR.3.3 Solve real-world problems involving the volume of right rectangular prisms, including problems with an unknown edge length, with whole number edge lengths using a visual model or a formula. Write an equation with a variable for the unknown to represent the problem.</p> <p>Example: A hydroponic box, which is a rectangular prism, is used to grow a garden in wastewater rather than soil. It has a base of 2 feet by 3 feet. If the volume of the box is 12 cubic feet, what would be the depth of the box?</p> <p>Clarification 1: Instruction progresses from right rectangular prisms to composite figures composed of right rectangular prisms.</p> <p>Clarification 2: When finding the volume of composite figures composed of right rectangular prisms, recognize volume as additive by adding the volume of non-overlapping parts. Clarification 3: Responses must include the appropriate units in word form.</p>		Real-world	<p>Items involving composite shapes must contain a graphic of the figures. Items involving composite shapes may contain no more than two non-overlapping prisms. Non-overlapping means that two prisms may share a face, but they do not share the same volume. Measuring units will not have exponents (<math>cm^3</math>, etc.).</p>
ALD 2	ALD 3	ALD 4	ALD 5
Solves real-world problems involving the volume of right rectangular prisms, including problems	Solves real-world problems involving the volume of right rectangular prisms, including problems with	Solves real-world problems involving the volume of right rectangular prisms, including problems with	Solves real-world problems involving the volume of composite figures

with an unknown edge length, with whole-number edge lengths not greater than 3 using a visual model.	an unknown edge length, with whole-number edge lengths not greater than 5 using a visual model or a formula; writes an equation with a variable for the unknown to represent the problem.	an unknown edge length, with whole-number edge lengths using a visual model or a formula; writes an equation with a variable for the unknown to represent the problem.	with an unknown edge length and whole-number edge lengths
--	---	--	---

Additional Resources:

[CPALMS MA.5.GR.3.3 -](#)

LearnZillion: [Find volume by multiplying the area of the base by the height | LearnZillion](#)

LearnZillion: [Find the volume of complex rectangular prisms | LearnZillion](#)

Khan Academy: [Volume through decomposition \(video\) | Khan Academy](#)

Resources/Tasks to Support Your Child at Home:

- Look around the house for objects that are shaped like rectangular prisms. *For example: cereal boxes, tissue boxes, shoeboxes, etc.* Measure the length, width, and height of each rectangular prism to the nearest inch, foot, or centimeter. Use the measurements to calculate the volume of each.

Guiding Questions:

How did you find the volume of each prism?

What does  $B$  mean in the volume formula?

Find the volume of rectangular prisms found at home: *cereal box, tissue box, shoe box, etc.* Find and compare the volume of rectangular prisms (boxes) found. Put two prisms together. Find the volume of the new shape.

### Example

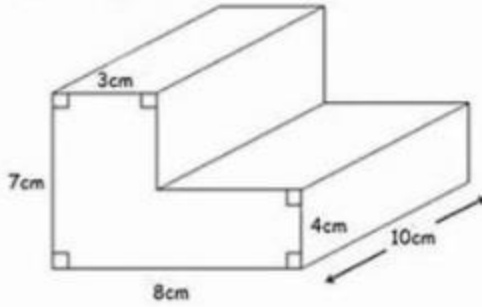

What is one way to decompose this complex figure into two rectangular prisms?

What is another way this figure could be decomposed?

What is the volume of the complex figure?